



Operator's Manual

Concrete Cutter CC140 Series



Table of Contents

- 1. SAFETY INFORMATION..... 2**
- 1.1 Operating Safety.....2
- 1.2 Operator Safety while using Internal Combustion Engines.....3
- 1.3 Diamond Blade Safety.....3-4
- 1.4 Transportation Safety.....4
- 1.5 Maintenance Safety4
- 1.6 Label Locations.....5
- 1.7 Safety and Operating Labels.....6-7

- 2. OPERATION 8**
- 2.1 Operation Principle8
- 2.2 Delivery Checks8
- 2.3 Application-Standard Features8
- 2.4 Cutting depth setting9
- 2.5 Depth of cut indicator9
- 2.6 Water tank9
- 2.7 Assembling the cutting blade
- 2.8 Before Starting9
- 2.9 To Start9
- 2.10 To Stop9

- 3. MAITENANCE 10**
- 3.1 Periodic Maintenance Schedule.....10
- 3.2 Transporting Cutters.....11
- 3.3 Belt Checking11
- 3.3 Trouble Shooting12

- 4. TECHNICAL DATA 13**

1. SAFETY INFORMATION

1.1 Operating Safety

- Only trained personnel are permitted to start, operate, and shut down the machine. They have received instruction on how to properly use the machine and are familiar with required safety devices
- The machine must not be accessed or operated by children and people impaired by alcohol or drugs.
- NEVER operate this machine in application for which it is not intended.
- NEVER allow anyone to operate this equipment without proper training. People operating this equipment must be familiar with the risks and hazards associated with it.
- NEVER operate the machine with the belt guard missing. Exposed drive belt and pulleys create potentially dangerous hazards that can cause serious injuries.
- DO NOT allow anyone to stand or lean on the unit during operation.
- Do not run the machine indoors or in an enclosed area such as a deep trench unless adequate ventilation, through such items as exhaust fans or hoses, is provided. Engine exhaust contains carbon monoxide. This is a poison you cannot see or smell. Exposure to carbon monoxide can cause loss of consciousness and CAN KILL YOU IN MINUTES.
- Do not operate the machine with unapproved accessories or attachments.
- ALWAYS wear protective clothing appropriate to the job site when operating the machine.
- ALWAYS close fuel valve on engines equipped with one when machine is not being operated.
- ALWAYS store the machine properly when it is not being used. The machine should be stored in a clean, dry location out of the reach of children.
- Before starting operation, check that all control and safety devices are functioning properly.
- Never operate the machine in a potentially explosive environment.
- Never leave the machine running unattended!
- Incorrect operation or misuse by untrained personnel can endanger the health and safety of the operator or third persons and also cause machine and material damage.
- Read, understand, and follow procedures in the Operator's Manual before attempting to operate the machine.

1.2 Operator Safety while using Internal Combustion Engines

- DO NOT smoke when refueling the engine or during any other fuel handling operation.
- DO NOT refuel a hot or running engine.
- DO NOT refuel the engine near an open flame.
- DO NOT spill fuel when refueling the engine.
- Do not touch the engine or muffler while the engine is on or immediately after it has been turned off. These areas get hot and may cause burns.

- If fuel is spilled during refueling, wipe it off from the engine immediately and discard the rag in a safe place. Do not operate the unit if fuel or oil leaks exist-repair immediately.
- NEVER operate this equipment in an explosive atmosphere.
- NEVER operate any gas powered equipment in a poorly ventilated or enclosed area.
- NEVER perform any work on the unit while it is running. Before working on it, stop the engine and disconnect the spark plug wire to prevent accidental starting.
- Avoid prolonged breathing of exhaust gases.
- Avoid contact with hot exhaust systems and engine parts.
- Allow engine to cool before performing any repairs or service.
- ALWAYS transport and handle fuel only when contained in approved safety containers.
- ALWAYS keep the area around the muffler free of debris such as leaves, paper, cartons, etc. A hot muffler could ignite the debris and start a fire.

1.3 Diamond Blade Safety

- Use appropriate steel centered diamond blades manufactured for use on concrete cutters.
- Always inspect diamond blades before each use. The blade should exhibit no cracks, dings, or flaws in the steel centered core and/or rim. Center (arbor) hole must be undamaged and true.
- Examine blade flanges for damage, excessive wear and cleanliness before mounting blade. Blade should fit snugly on the shaft and against the inside/outside blade flanges.
- Ensure that the blade is marked with an operating speed greater than the blade shaft speed of the cutter.
- Only cut the material that is specified by the diamond blade. Read the specifications of the diamond blade to ensure the proper tool has been matched to the material being cut.
- Always keep blade guards in place. Exposure of the diamond blade must not exceed 180 degrees.
- Ensure that the diamond blade does not come into contact with ground or surface during transportation. Do not drop the diamond blade on ground or surface.
- The engine governor is designed to permit maximum engine speed in a no-load condition. Speeds that exceed this limit may cause the diamond blade to exceed the maximum safe allowable speed.
- Ensure that the blade is mounted for proper operating direction.

1.4 Transportation Safety

- Use the lifting bail and appropriate lifting equipment to ensure the safe movement of the cutter.
- Do not use the handle bars and/or front pointer as lifting points.
- Never tow the saw behind a vehicle.
- Ensure that both pointer bars are positioned appropriately to minimize their exposure

during transportation.

- Safeguard against extreme cutter attitudes relative to level. Engines tipped to extreme angles may cause oil to gravitate into the cylinder head making the engine difficult to start.
- Never transport the cutter with the blade mounted.

1.5 Maintenance Safety



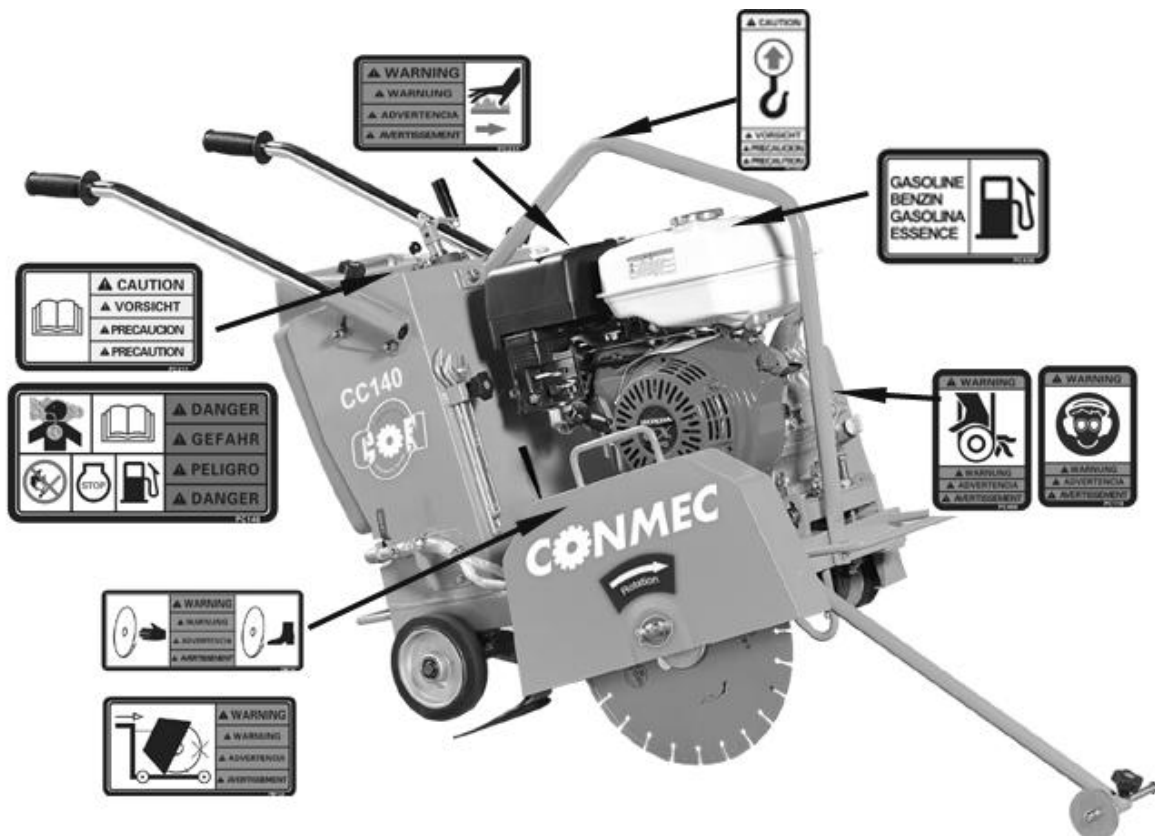

- Never lubricate components or attempt service on a running machine.
- Always allow the machine a proper amount of time to cool before servicing.
- Keep the machinery in running condition.
- Fix damage to the machine immediately and always replace broken parts.
- Dispose of hazardous waste properly. Examples of potentially hazardous waste are used motor oil, fuel and fuel filters.
- Do not use food or plastic containers to dispose of hazardous waste.





1.6 Label Location



1.7 Safety and Operating Labels

CONMEC machines use international pictorial labels where needed. These labels are described below:

Label	Meaning
	<p>DANGER! Engines emit carbon monoxide; operate only in well-ventilated area. Read the Operation Manual for machine information. No sparks, flames, or burning objects near the machine. Shut off the engine before refueling. Use only clean, filtered unleaded gasoline.</p>
	<p>WARNING! Cutting hazard. Always replace blade guard!</p>
	<p>WARNING! Machine may not be offset with the cutting blade rotating.</p>
	<p>CAUTION! Read and understand the supplied Operator's Manual before operating the machine. Failure to do so increase the risk of injury to yourself or others.</p>
	<p>WARNING! Always wear hearing and eye protection when operating this machine.</p>

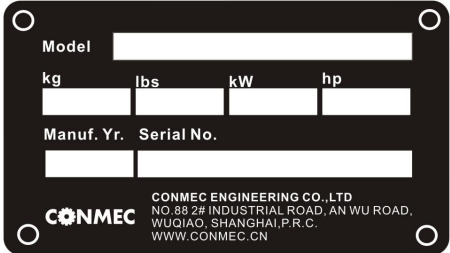
Label	Meaning
	<p>WARNING! Hand injury if caught in moving belt. Always replace belt guard.</p>
	<p>CAUTION! Lifting point.</p>
	<p>CAUTION! Use only clean, filtered fuel.</p>
	<p>WARNING! Hot surface!</p>
	<p>A nameplate listing the model number and serial number is attached to each unit. Please record the information found on this plate so it will be available if the nameplate is lost or damaged. When requesting service information, the serial number should be specified of the unit.</p>

2. OPERATION

2.1 Operating Principle

The following instructions were compiled to provide you information on how to obtain long and trouble free use of the machine. Periodic maintenance of the machine is essential. Read the manual carefully and thoroughly familiarize yourself with the machine and all it's functions. Failure to do so may injure yourself or a bystander.

2.2 Delivery Checks

Immediately on taking delivery of your new machine and before putting it into service.

- Read the operator's manual completely—it could save a great deal of unnecessary expense. Read the engine manual supplied.
- Check the general condition of the machine – has it been damaged during delivery?
- Check engine oil level.
- Check fuel level.

Recommended lubricants are detailed in the Care and Maintenance section.

2.3 Application-Standard Features

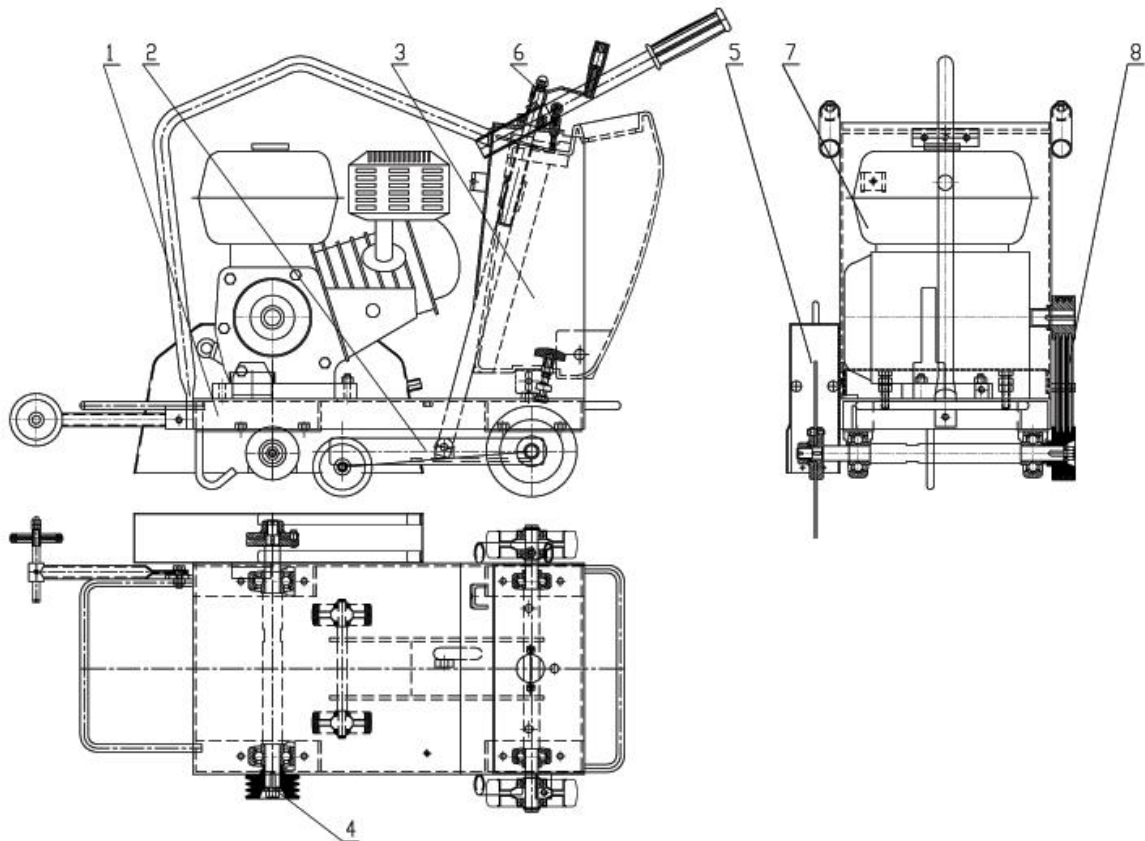

Ref. No.	Description	Ref. No.	Description
1	Frame	5	Blade Guard
2	Wheel Shaft	6	Crank
3	Water Tank Assy.	7	Engine
4	Shaft Assy.	8	Belt

2.4 Cutting depth setting

With the crank you can set the cutting depth precisely. Turn the crank in the clockwise direction to increase the cutting depth and turn it in the counterclockwise direction to reduce the cutting depth.

2.5 Depth of cut indicator

You can use the indicator to check the cutting depth currently set. It features a cm-scale. You have to adjust it to the diameter of the blade currently installed to obtain the correct value. To do this, turn the crank until the blade touches the ground, loosen the clamp and push the sleeve with the scale up to the bottom of the sleeve. Then tighten the clamp again.

2.6 Water tank

The concrete cutter features an integrated, removable water tank.

To fit the water tank, attach the retaining clamp and tighten it with the strap.

To remove the water tank or to attach an external water supply, you can disconnect the hose on two different spots.

The amount of water can be regulated or stopped.

2.7 Assembling the cutting blade

1. Checking a new cutting blade:

- The blade type must be suitable for the material to be cut. Observe the peripheral speed, refer to the "Technical data"!
- The arbor diameter of the cutting blade must precisely fit the shaft to ensure smooth blade running.
- The cutting blade must be undamaged.

NOTICE: Observe the correct direction of rotation of the cutting blade! That means the rotational direction mark on the cutting blade must correspond with the rotational direction mark on the cutting blade guard.

2. Fold up the cutting blade guard.

3. Prior to the assembly of the cutting blade, clean the spring washers and the locking pin and check them for damage.

4. Attach cutting blade and spring washer on the shaft.

5. Tighten the hexagonal bolt firmly. To do this, apply counter pressure on the spanner surfaces of the cutting shaft.

6. Fold down the cutting blade guard.

NOTICE: Starting the machine is only permitted with a water hose connected and the water supply turned on.

2.8 Before Starting

Before starting the machine, check the following items:

- All handles are free from grease, oil and dirt.
- All control levers are in the neutral position.
- All bolted joints are tightened.
- Fuel level
- Oil level in the engine
- Air cleaner maintenance indicator

NOTICE: Check the oil level in the engine and machine before starting. The warranties are VOID if the machine run without oil.

2.9 To Start

1. Start engine and let engine warm up. All cutting is done at full throttle.
2. Align blade and cutter with cut. Open water valve and turn water safety switch on.
3. Lower blade into cut slowly.
4. Cut as fast as blade will allow. If blade climbs out of cut, reduce forward speed or depth of cut.
5. Use only enough side pressure on cutter handles to follow cutting line.

2.10 To Stop

Petrol Engine – close throttle all the way and flip oil minder kill switch to off position.

Diesel Engine – close throttle all the way, depress kill switch button and hold down until engine stops completely.

3 MAINTENANCE

3.1 Periodic Maintenance Schedule

The chart below lists basic trowel and engine maintenance. Refer to engine manufacturer's Operator's Manual for additional information on engine maintenance. A copy of the engine Operator's Manual was supplied with the machine when it was shipped. To service the engine, tilt the seat forward.

	Daily	Every 20 hours	Every 50 hours	Every 100 hours	Every 200 hours	Every 300 hours
Check fuel level.	●					
Check engine oil level.	●					
Inspect air filter. Replace as needed.	●					
Check external hardware.	●					
Replace the engine oil		●				
Clean air filter		●				
Check drive belt for wear.			●			
Change engine oil.				●		
Check fuel filter.				●		
Clean and check spark plug.					●	
Replace oil filter.					●	
Replace spark plug.						●
Replace fuel filter.						●
Check the cutting blade for damage and tightness	●					
Check the direction of rotation arrow of the cutting blade	●					
Check that the height adjustment moves freely	●					
Check the water supply	●					

3.2 Transporting the cutter

- Always shut off engine when transporting machine.
- Make sure lifting device has enough capacity to hold machine (see identification plate on machine for weight).
- Use lifting hook (a) when lifting machine.



3.3 Belt Checking

Check the belt in the course of the weekly engine maintenance and retighten it as follows, if necessary:

1. Remove the belt guard.
2. Loosen the jam nut.
3. Loosen the four fastening nuts of the engine until the engine can be moved without play.
4. Tighten the belt with the tension screw.
5. If necessary, correct the parallel alignment of the engine. As a first step, tighten a fastening nut of the engine and correct the alignment by means of the tension screw.
6. Tighten all fastening nuts of the engine as well as the jam nut.
7. Mount the belt guard.

3.4 Trouble Shooting

SYMPTOM	POSSIBLE CAUSES	SOLUTION
Engine running rough or not at all.	Fuel?	Look at the fuel system. Make sure there is fuel being supplied to the engine. Check to ensure that the fuel filter is not clogged.
	Ignition?	Check to ensure that the ignition switch has power and is functioning correctly.
Engine does not start	The main switch is in the "0" position.	Set the main switch to the "I" position.
	Fuel tap is closed.	Open the fuel tap.
	Fuel tank is empty.	Top up with fuel.
	Fuel line is clogged.	Have the fuel line cleaned.
	Fuel filter is clogged.	Have the fuel filter replaced.
	Carburetor is clogged.	Have the carburetor cleaned.
	Air cleaner is clogged.	Clean or replace air cleaner.
	Spark plug cap is defective.	Have the machine repaired.
	Spark plug is defective.	Change the spark plug.
	Spark plug is loose.	Tighten the spark plug.
	Spark plug gap is set incorrectly.	Set the spark plug gap.
Insufficient engine oil.	Top up with engine oil.	
Engine shuts off right after starting.	Idle speed is adjusted incorrectly.	Set idle speed.
	Fuel tank is empty.	Top up with fuel.
	Fuel filter is clogged.	Have the fuel filter replaced.
	Air cleaner is dirty.	Clean or replace air cleaner.
	Insufficient engine oil.	Top up with engine oil.
Engine has low performance.	Air cleaner is dirty.	Clean or replace air cleaner.
Recoil starter defective.	Starter rope jammed.	Have the starter rope replaced.
	Starter rope torn off.	
Cutting blade does not rotate.	The belt is faulty.	Replace the belt.
Engine cannot be turned off.	Electrical connection of the main switch is defective.	<ol style="list-style-type: none"> 1. Close the fuel tap. The engine will switch off after a few seconds. 2. Have the machine repaired.

4. TECHNICAL DATA

Model		CC140-1	CC140-2	CC140-3	CC140-4
Engine type		Diesel, KM186F	Chinese Petrol Engine	Robin EX27	Honda GX270
Power	kw(hp)	6.6(9.0)	6.6(9.0)	6.6(9.0)	6.6(9.0)
Weight	kg(lb)	109(240)	91(200)	87(191)	87(191)
Max. cutting Depth	cm(in)	12(4.7)			
Blade Size	cm(in)	30-35(12-14)			
Water Tank Capacity	L	25			
Depth Adjustment		Handle Rotation			
Driving		Manual Push			

Working Size (L x W x H): 1840mm x 500mm x 780mm

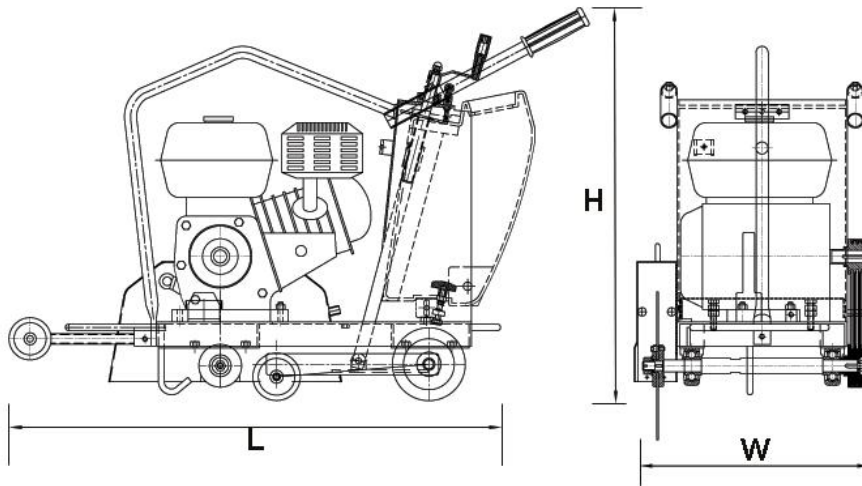

Sound Specification (According to DIN EN 13862):

The sound pressure level measured (LpA): 103 dB(A)

The guaranteed sound power level (LWA): 105 dB(A)

Vibration Specification (According to DIN EN 13862):

Uncertainty of measurement of vibration total value a_{hv} : 1.6m/s²



CONMEC ENGINEERING CO., LTD

Add: No.88, 2# Industrial Avenue, An Wu Road,
Wu Qiao County, Feng Xian, Shanghai, P.R.C

Tel: 86 (0)21 57407318

Fax: 86 (0)21 57406955

E-mail: sales@conmec.cn

www.conmec.cn

Version: 20120101