



**Operator's Manual**

**Walk-behind Power Trowel**

**CT436 Series**

**CT442 Series**

**CT446 Series**



---

Manufacturer

Conmec Engineering Co., Ltd  
No.88, 2# Industrial Avenue, An Wu Road,  
Wu Qiao County, Feng Xian, Shanghai, P.R.C  
Tel: 86 (0)21 57407318 Fax: 86 (0)21 57406955  
[www.conmec.cn](http://www.conmec.cn)

---

Original instructions

This Operator's Manual presents the original instructions. The original language of the Operator's Manual is English.

---

## **Foreword**

This manual contains important instructions for this machine. These instructions must be followed during installation, operation, and maintenance of the machines.

This manual provides information and procedures to safely operate. For your own safety and to reduce the risk of injury, carefully read, understand, and observe all instructions described in this manual.

We reserves the right to change any of the contents in this manual without notice.

## **Warranty**

Our products are covered by warranty for a period of twelve (12) months from the date of purchase against defects in material or workmanship provided that:

- The product concerned has been operated and maintained in accordance with the operating instructions.
- Has not been damaged by accident, misuse or abuse.
- Has not been tampered with or repaired by any unauthorized person.

Any evidence of failure to meet these conditions may result in a denial of the warranty claim.

The owner is responsible for the cost of transportation to and from the authorized repairer and the unit is at the owners risk while in transit to and from the repairer.

Impact damage is not covered under warranty. Clutches are not covered under any warranty.

Engines are officially guaranteed by engine manufacturer. Please refer to the annex for engine warranty.

# Table of Contents

<b>Foreword</b>	<b>3</b>
<b>Warranty</b>	<b>3</b>
<b>1. SAFETY INFORMATION</b>	<b>5</b>
1.1 Machine Description and Intended Use .....	5
1.2 Operating Safety.....	5
1.3 Operator Safety while using Internal Combustion Engines.....	6
1.4 Service Safety .....	6
1.5 Label Locations.....	7
1.6 Labels Meaning .....	8-9
<b>2. OPERATION</b>	<b>10</b>
2.1 Preparing the Machine for First Use .....	10
2.2 Controls .....	10
2.3 Installing the Blades .....	11
2.4 Before Starting .....	11
2.5 Handle Installation and Adjusting .....	12
2.6 Safety Stop Switch .....	12
2.7 To Start .....	13
2.8 To Stop .....	13
2.9 Pitch Adjustment .....	13
2.10 Floating Operation.....	13
2.11 Finishing Operation.....	13
<b>3. MAINTENANCE</b>	<b>14</b>
3.1 Periodic Maintenance Schedule.....	14
3.2 Lubrication.....	15
3.3 Lifting and Transporting Trowels.....	15
3.4 Trouble Shooting .....	16
<b>4. TECHNICAL DATA</b>	<b>17</b>
4.1 Technical Specification.....	17
4.2 Dimension .....	18
4.3 Sound and Vibration Specification .....	18
<b>EC Declaration of Conformity</b>	<b>19</b>

# 1. SAFETY INFORMATION

## 1.1 Machine Description and Intended Use

This machine is a walk-behind concrete finishing trowel. It consists of a engine mounted frame, a gasoline engine, a gearbox, a guard ring and a handle.

This machine is intended to be used for floating and burnishing curing concrete.

## 1.2 Operating Safety

- Only trained personnel are permitted to start, operate, and shut down the machine. They have received instruction on how to properly use the machine and are familiar with required safety devices.
- Read, understand, and follow procedures in the Operator's Manual before attempting to operate the machine.
- The machine must not be accessed or operated by children and people impaired by alcohol or drugs.
- NEVER operate this machine in application for which it is not intended.
- NEVER operate the machine with the belt guard missing. Exposed drive belt and pulleys create potentially dangerous hazards that can cause serious injuries.
- NEVER allow anyone to operate this equipment without proper training. People operating this equipment must be familiar with the risks and hazards associated with it.
- Do not operate the machine with unapproved accessories or attachments.
- Do not allow anyone to stand or lean on the unit during operation.
- Do not run the machine indoors or in an enclosed area such as a deep trench unless adequate ventilation, through such items as exhaust fans or hoses, is provided. Engine exhaust contains carbon monoxide. This is a poison you cannot see or smell. Exposure to carbon monoxide can cause loss of consciousness and CAN KILL YOU IN MINUTES.
- Do not touch the engine or muffler while the engine is on or immediately after it has been turned off. These areas get hot and may cause burns.
- ALWAYS Keep the safety stop switch system in adjustment and good operating condition at all times. Do not operate the trowel if it does not work properly. Out of control Trowels can cause serious personal injury and damage to fresh concrete surfaces. This system will automatically stop the unit if the operator loses control of it during operation.
- ALWAYS make sure the safety stop switch is disengaged (lever in the down position) before starting the unit. Keep one hand firmly on the handle while starting and do not let go of the handle during operation.
- ALWAYS wear protective clothing, safety glasses, hearing protection, safety-toed footwear to the job site while operating the machine.
- ALWAYS close fuel valve on engines equipped with one when machine is not being operated.
- ALWAYS store the machine properly when it is not being used. The machine should be stored in a clean, dry location out of the reach of children.

### 1.3 Operator Safety while using Internal Combustion Engines

- Do not smoke when refueling the engine or during any other fuel handling operation.
- Do not run the engine near sparks or open flames.
- Do not start the engine if fuel has spilled or a fuel odor is present. Move the machine away from the spill and wipe the machine dry before starting.
- Do not refuel a hot or running engine.
- Do not refuel the engine near sparks or open flames.
- Do not spill fuel when refueling the engine.
- Do not touch the engine or muffler while the engine is on or immediately after it has been turned off. These areas get hot and may cause burns.
- If fuel is spilled during refueling, wipe it off from the engine immediately and discard the rag in a safe place. Do not operate the unit if fuel or oil leaks exist-repair immediately.
- NEVER operate this equipment in an explosive atmosphere.
- NEVER operate any gas powered equipment in a poorly ventilated or enclosed area.
- NEVER perform any work on the unit while it is running. Before working on it, stop the engine and disconnect the spark plug wire to prevent accidental starting.
- Avoid prolonged breathing of exhaust gases. You may be hurt by harmful exhausted gases.
- Avoid contact with hot exhaust systems and engine parts.
- Allow engine to cool before performing any repairs or service.
- ALWAYS transport and handle fuel only when contained in approved safety containers.
- ALWAYS keep the area around the muffler free of debris such as leaves, paper, cartons, etc. A hot muffler could ignite the debris and start a fire.





### 1.4 Service Safety

- Read and understand the instructions contained in the manual delivered with the machine before servicing or maintaining
- Familiarize yourself with the location and proper use of all controls and safety devices before servicing or maintaining.
- Contact local dealer for additional training if necessary.
- Do not allow improperly trained people to service or maintain the machine. Personnel servicing or maintaining the machine must be familiar with the associated potential risks and hazards.
- Do not attempt to clean or service the machine while it is running. Rotating parts can cause severe injury.
- Do not remove blades while the machine is hanging overhead.
- Disconnect the spark plug on machines equipped with gasoline engines, before servicing, to avoid accidental start-up.
- When replacement parts are required for this machine, use only our replacement parts or those parts equivalent to the original in all types of specifications, such as physical dimensions, type, strength, and material.







## 1.6 Label Meanings

Our machines use international pictorial labels where needed. These labels are described below:

Label	Meaning
	<p><b>DANGER!</b> Engines emit carbon monoxide; operate only in well-ventilated area. Read the Operator's Manual for machine information. No sparks, flames, or burning objects near the machine. Shut off the engine before refueling. Use only clean, filtered unleaded gasoline.</p>
	<p><b>WARNING!</b> Cutting hazard. Always replace blade guard!</p>
	<p><b>CAUTION!</b> Read and understand the supplied Operator's Manual before operating the machine. Failure to do so increase the risk of injury to yourself or others.</p>
	<p><b>WARNING!</b> Always wear hearing and eye protection when operating this machine.</p>

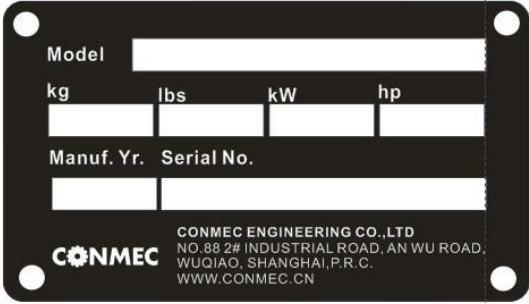

Label	Meaning
	<p><b>WARNING!</b> Hand injury if caught in moving belt. Always replace belt guard.</p>
	<p><b>CAUTION!</b> Lifting point.</p>
	<p><b>CAUTION!</b> Use only clean, filtered fuel.</p>
	<p><b>WARNING!</b> Hot surface!</p>
	<p>A nameplate listing the model number and serial number is attached to each unit. Please record the information found on this plate so it will be available if the nameplate lost or damaged. When requesting service information, the serial number should be specified of the unit.</p>

## 2. OPERATION

### 2.1 Preparing the Machine for First Use

- 2.1.1 Make sure all loose packaging materials have been removed from the machine.
- 2.1.2 Check the machine and its components for damage. If there is visible damage, do not operate the machine! Contact dealer immediately for assistance.
- 2.1.3 Take inventory of all items included with the machine and verify that all loose components and fasteners are accounted for.
- 2.1.4 Add fluids as needed and applicable, including fuel, engine oil, and battery acid.

### 2.2 Controls

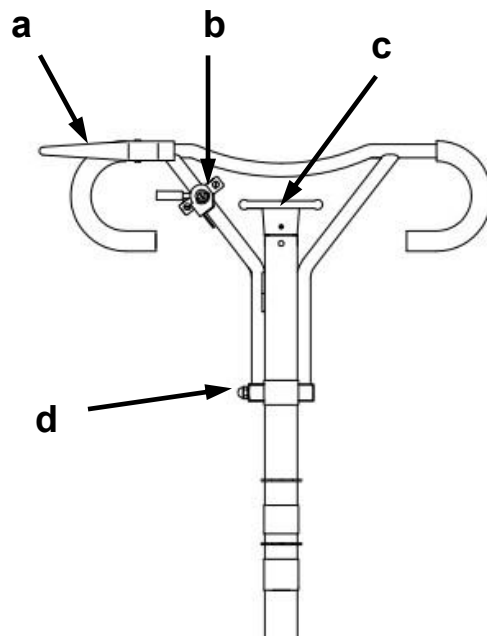

Ref. No.	Description	Ref. No.	Description
a	Safety stop switch	c	Twist pitch control knob
b	Throttle lever	d	Handle height adjustment knob

## 2.3 Installing the Blades

There are three types of blades available for the trowels. Float pans are large style blades, which hook on over finish or combination blades, used in the earliest stages of work, and are not pitched.

Finishing blades are used in the final stages of working, and are progressively pitched to burnish the concrete.

Combination blades can be used throughout the concrete working process. They are used in place of float pans and finishing blades.

**Note:** Do not put larger diameter blades on a smaller diameter trowel.

2.3.1 Finishing blades are flat on both edges and can be installed in either direction.

2.3.2 When installing combination blades, orient blades as bellow. This positions the raised edges of the blade correctly for the clockwise rotation of the machine.

2.3.3 Secure blades to trowel arms with screws (a). Dip threads of screws in grease prior to installation. This will prevent concrete from cementing the screws in place and will make removal of the blades easier later on.

**Warning:** Do not lift the trowel overhead with a float pan attached, as the pan could fall off and strike personnel working in the vicinity.

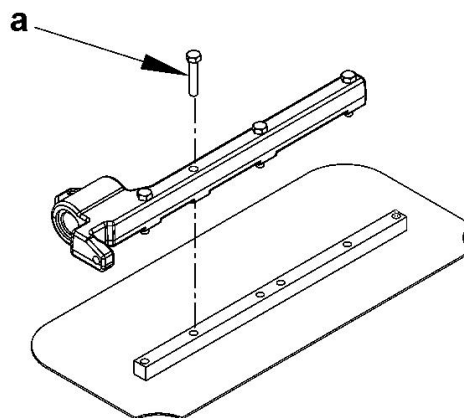

## 2.4 Before Starting

Before starting the machine, check the following items:

- All handles are free from grease, oil and dirt.
- All control levers are in the neutral position.
- All bolted joints are tightened.
- Fuel level
- Oil level in the engine
- Oil level in gearbox
- Air cleaner maintenance indicator
- Condition of Ring Guard
- Condition of trowel arms and blades

**NOTICE:** Check the oil level in the engine and machine before starting. The warranties are VOID if the machine run without oil.

## 2.5 Handle Installation and Adjusting

- 2.5.1 Un-pack the handle assembly and the lower unit from the boxes. Check to make sure no damage was done during shipment. Mount the handle assembly to the gearbox on the lower unit using 10mm nuts that are supplied in a package on the lower unit.
- 2.5.2 Pull the pitch control cable (A) from bottom end of the tube and remove the cable nut (B) from the cable. Push the control knob (C) all the way forward (away from the operator) or turn the twist pitch control handle counterclockwise as far as possible. Connect the cable to the yoke (D) as shown and adjust the cable nut so the cable is snug and the trowel blades lay flat (0° pitch).
- 2.5.3 Move throttle to idle position. Remove air cleaner cover. Feed cable through clamp on recoil cover. Connect throttle cable to engine throttle bracket by placing z-bend through hole in throttle plate. Clamp cable into throttle casing bracket. Replace air cleaner cover.
- 2.5.4 On machines with an adjustable handle, position the handle by loosening the knob (E) and adjusting the handle up or down to suit the operator. Tighten the knob to secure the handle in position.

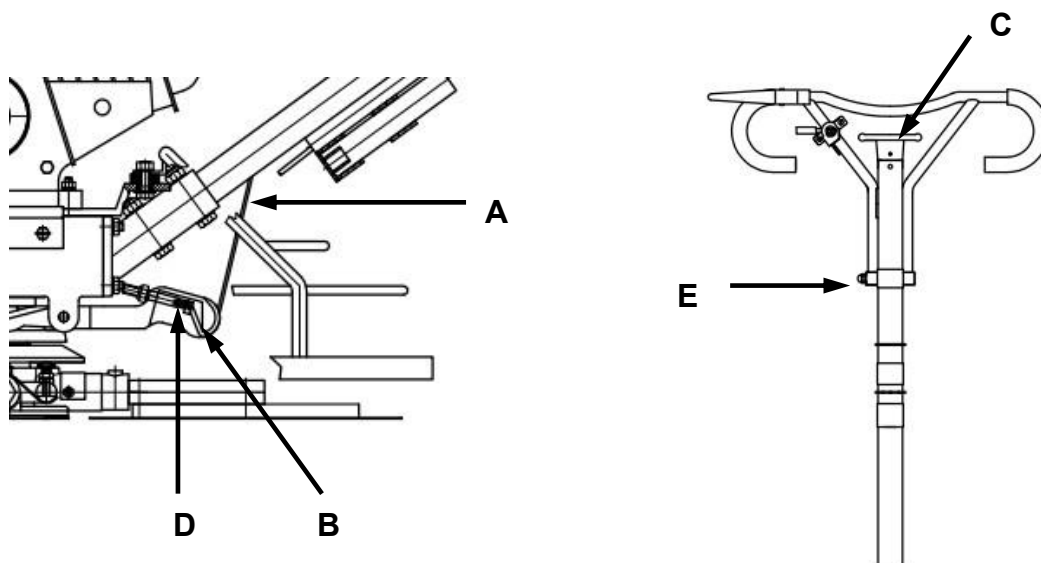

## 2.6 Safety Stop Switch

The switching mechanism of this switch should operate freely and should always be kept in this condition. With the switch in the OFF position, the engine should not start or run. The purpose of this switch is to stop the engine in a runaway situation, (i.e. the operator releasing the handle during operation).

## 2.7 To Start

Before starting the machine must know the location and function of all controls. Make sure the safety stop switch is in the stop position. If it is not, push the lever down to the stop position before attempting to start the engine.

### 2.7.1 Open fuel valve under fuel tank

**Note:** If engine is cold, move choke lever to closed position. If engine is hot, set choke to open position.

### 2.7.2 Turn engine switch to "ON".

### 2.7.3 Move the throttle lever to the idle position.

### 2.7.4 Pull starter rope.

**Warning:** Do not place foot on the ring guard when starting the engine, as severe injury can occur if foot slips through the ring guard as the blades start to spin.

### 2.7.5 Open choke as engine warms.

### 2.7.6 Open throttle and safety stop switch to operate trowel. Adjust blade RPM with throttle speed to suit conditions.

## 2.8 To Stop

Reduce engine RPM to idle by moving the throttle lever to idle position. Release the safety stop switch. Turn engine switch to "OFF".

## 2.9 Pitch Adjustment

To adjust blade pitch (angle) by twist pitch control knob. Turning the knob clockwise to increases the pitch of the blades. Turning the knob counter-clockwise flattens or decreases the pitch of the blades.

## 2.10 Floating Operation

Attach float blades to the trowel arms, and when the concrete has set sufficiently to support the weight of the trowel, place the unit on the concrete. Start the unit and engage the blades as previously instructed. Using the tilt adjustment knob to adjust the blades to the float position-blades should be as flat to the concrete as possible with enough tension kept on the tilt adjustment cable to prevent the unit from dancing or chattering.

This operation will bring the water and fines to the surface, allowing for a smoother finish when finishing the concrete.

## 2.11 Finishing Operation

After floating, allow the concrete to set until it will support the weight of the trowel. Set the pitch to approximately 1/4" to 3/8" on the blades. If the blades start to dig into the concrete, decrease the amount of pitch.

### 3 MAINTENANCE

#### 3.1 Periodic Maintenance Schedule

The chart below lists basic trowel and engine maintenance. Refer to engine manufacturer's Operator's Manual for additional information on engine maintenance. A copy of the engine Operator's Manual was supplied with the machine when it was shipped. To service the engine, tilt the seat forward.

	Daily	Every 20 hours	Every 50 hours	Every 100 hours	Every 200 hours	Every 300 hours
Check fuel level.	●					
Check engine oil level.	●					
Inspect air filter. Replace as needed.	●					
Check external hardware.	●					
Clean trowel after each use to remove concrete splatter.	●					
Replace the engine oil		●				
Grease blade arms		●				
Clean air filter		●				
Thrust collar and clutch. Replace blade if necessary		●				
Check drive belt for wear.			●			
Change engine oil.				●		
Check fuel filter.				●		
Clean and check spark plug.					●	
Replace oil filter.					●	
Replace spark plug.						●
Replace fuel filter.						●
Adjust blade speed						●
Replace oil in gearboxes.						●

### 3.2 Lubrication

The long life and successful operation of any parts of machinery is dependent on frequent and thorough lubrication. Before using the machine, always check the oil and use proper oil with the correct type and grade as recommended.

NOTICE: DO NOT mix types of oil in gearbox and DO NOT overfill the oil. Damage to the machine may occur if oils are mixed or overfilled. See Technical Data for oil quantity and type.

### 3.3 Lifting and Transporting Trowels

#### 3.3.1 Lifting the trowels

Remove the auxiliary lifting tube located on top of the main handle. Insert the tube into the socket located on the opposite side of the gearbox from the handle.

Make sure that the hole in the tube engages with the pin in the socket. With one person lifting from the main handle, and another lifting from the auxiliary lifting tube pick up the machine to move onto a slab.

Use and lifting hook(if equipped) when lifting machine. Make sure lifting device has enough capacity to hold machine (see identification plate on machine for weight).

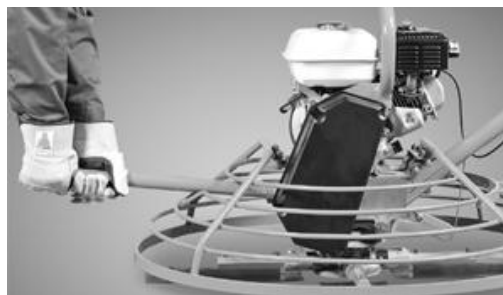
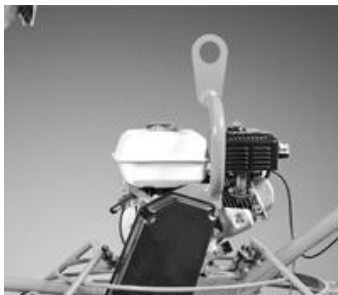

3.3.2 Use the trolley wheel for short distance transportation.



### 3.4 Trouble Shooting

SYMPTOM	REMEDY
Engine running rough or not at all.	<ul style="list-style-type: none"> <li>● Make sure that the safety switch is ON or replace switch if necessary.</li> <li>● Look at the fuel system. Make sure there is fuel being supplied to the engine. Check to ensure that the fuel filter is not clogged.</li> <li>● Check to ensure that the ignition switch has power and is functioning correctly.</li> <li>● Check fuel level. Open fuel valve.</li> <li>● Clean air filter.</li> <li>● Check /replace spark plug.</li> <li>● Check engine oil level.</li> <li>● Check that throttle is in idle position when starting machine.</li> </ul>
Trowel does not develop full speed.	<ul style="list-style-type: none"> <li>● Remove deposits built up in engine cylinder and engine head.</li> <li>● Engine speed too low. Adjust speed.</li> <li>● Clean or replace air filter.</li> <li>● Clean debris from moving parts and trowel blades.</li> <li>● In cold weather, warm engine in idle 3 or 4 minutes.</li> <li>● Check throttle lever and cable for proper operation.</li> </ul>
Engine runs, poor trowel operation	<ul style="list-style-type: none"> <li>● Check drive belt for wear or damage.</li> <li>● Check clutch for wear or damage.</li> <li>● Clean debris from moving parts and trowel arms.</li> </ul>
Machine has a perceptible rolling motion while running.	<ul style="list-style-type: none"> <li>● The main output shaft of the gearbox assembly should be checked for straightness. The main shaft must run straight and cannot be more than 0.003" (0.08mm) out of round at the spider attachment point.</li> <li>● Check to make sure that both fingers of the yoke press evenly on the wear cap. Replace yoke as necessary.</li> <li>● Check to ensure that each blade is adjusted to have the same pitch as all other blades. Adjust per maintenance section in manual.</li> </ul>



## 4. TECHNICAL DATA

### 4.1 Technical Specification

Model		CT436-2	CT436-3	CT436-4
Engine type		Chinese Petrol Engine	Robin EX17	Honda GX160
Power	kw(hp)	4.8(6.5)	4.2(5.7)	4.0(5.5)
Operating weight	kg(lb)	81(178)	80(176)	80(176)
Blade speed	rpm	70-150		
Rotor Dia.	cm(in)	92(36)		
Finishing Blade	in	6x14		
Combination Blade	in	8x14		
Float Pan	in	37		

Model		CT442-2	CT442-3	CT442-4
Engine type		Chinese Petrol Engine	Robin EX27	Honda GX270
Power	kw(hp)	6.6(9.0)	6.6(9.0)	6.6(9.0)
Operating weight	kg(lb)	98(216)	94(207)	98(216)
Blade speed	rpm	70-145		
Rotor Dia.	cm(in)	110(42)		
Finishing Blade	in	6X16		
Combination Blade	in	8x16		
Float Pan	in	43		

Model		CT446-2	CT446-3	CT446-4
Engine type		Chinese Petrol Engine	Robin EX27	Honda GX270
Power	kw(hp)	6.6(9.0)	6.6(9.0)	6.6(9.0)
Operating weight	kg(lb)	100(220)	96(211)	100(220)
Blade speed	rpm	70-145		
Rotor Dia.	cm(in)	116(46)		
Finishing Blade	in	6X18		
Combination Blade	in	8x18		
Float Pan	in	46		

## 4.2 Dimension

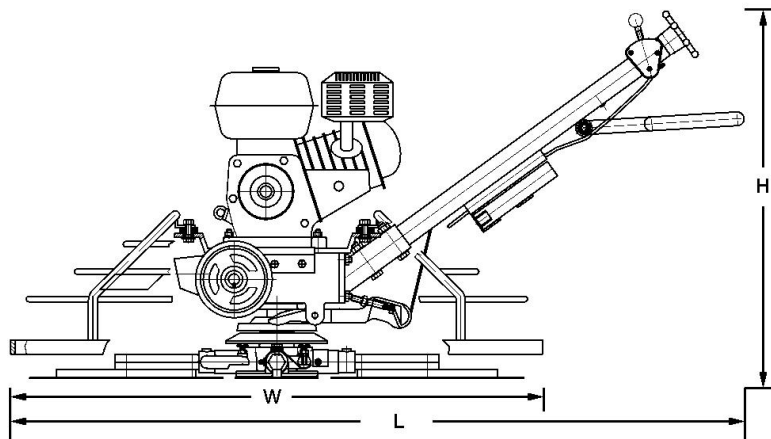

Model	L (mm)	W(mm)	H(mm)
CT436 Series	1960	990	900
CT442 Series	2200	1180	1020
CT446 Series	2250	1250	1020

## 4.3 Sound and Vibration Specification

### Sound Specification

The required sound specification:

	CT436 Series	CT442 Series	CT446 Series
The sound pressure level at operator's location ( $L_{pA}$ )	88dB(A)	90dB(A)	90dB(A)
The guaranteed sound power level ( $L_{WA}$ )	104dB(A)	102dB(A)	102dB(A)

These sound values were determined according to ISO 3744 for the sound power level ( $L_{WA}$ ) and ISO 11204 for the sound pressure level ( $L_{pA}$ ) at the operator's location.

### Vibration Specification

The weighted effective acceleration value, determined according to ISO 2361-1 and ISO 5349, is:

for **hand arm**:

CT436 Series: 1.6 m/s<sup>2</sup>

CT442 Series: 1.8 m/s<sup>2</sup>

CT446 Series: 1.82 m/s<sup>2</sup>

The sound and vibration specifications were obtained with the unit operating on fully cured, water wetted concrete at nominal engine.

**EC DECLARATION OF CONFORMITY  
CE-KONFORMITÄTSERKLÄUNG  
DECLARACIÓN DE CONFORMIDAD DE LA CE  
DÉCLARATION DE CONFORMITÉ C.E.**

**CONMEC ENGINEERING CO., LTD  
NO.88, 2# INDUSTRIAL AVENUE, AN WU ROAD, WU QIAO COUNTY,  
FENG XIAN, SHANGHAI, P.R.C**

hereby certifies that the construction equipment specified hereunder /bescheinigt, da. das Bauger.t/  
certifica que la máquina de construcción/atteste que le matériel :

1. Category / Art / Categoría / Catégorie:

Power Trowel

2. Type / Typ / Tipo / Type:

CT436-2, CT436-3, CT436-4,

CT442-2, CT442-3, CT442-4

CT446-2, CT446-3, CT446-4

has been produced in accordance with the following standards:/in übereinstimmung mit folgenden  
Richtlinien hergestellt worden ist:/ha sido fabricado en conformidad con las siguientes normas: / a été  
produit conformément aux dispositions des directives européennes ci-après :

2006/42/EC

2004/108/EC

EN12649



03.20.13

-----

Date / Datum / Fecha / Date

John Lee

Manager of Engineering



**CONMEC ENGINEERING CO., LTD**

Add: No.88, 2# Industrial Avenue, An Wu Road,  
Wu Qiao County, Feng Xian, Shanghai, P.R.C

Tel: 86 (0)21 57407318

Fax: 86 (0)21 57406955

E-mail: [sales@conmec.cn](mailto:sales@conmec.cn)

[www.conmec.cn](http://www.conmec.cn)